

# Clarke®



## INTELLIGENT BATTERY CHARGER/MAINTAINER

MODEL NO: IBC20

PART NO: 6267012

## OPERATION & MAINTENANCE INSTRUCTIONS



ORIGINAL INSTRUCTIONS

GC0918 - ISS 1

---

## INTRODUCTION

---

Thank you for purchasing this CLARKE Battery Charger.

Please read this manual thoroughly, before attempting to operate this product and carefully follow all instructions given.

It is vitally important that ALL precautions are taken, as specified, which will not only provide protection for yourself and that of others around you, but will also ensure that the battery charger will give you long and satisfactory service.

---

## GUARANTEE

---

This CLARKE product is guaranteed against faulty manufacture for a period of 12 months from the date of purchase. Please keep your receipt as proof of purchase.

This guarantee is invalid if the product is found to have been abused or tampered with in any way, or not used for the purpose for which it was intended.

Faulty goods should be returned to their place of purchase, no product can be returned to us without prior permission.

This guarantee does not effect your statutory rights.

---

## ENVIRONMENTAL RECYCLING POLICY

---



Through purchase of this product, the customer is taking on the obligation to deal with the WEEE in accordance with the WEEE regulations in relation to the treatment, recycling & recovery and environmentally sound disposal of the WEEE.

In effect, this means that this product must not be disposed of with general household waste. It must be disposed of according to the laws governing Waste Electrical and Electronic Equipment (WEEE) at a recognised disposal facility.

---

# SAFETY PRECAUTIONS

---



**WARNING: ALWAYS SWITCH OFF THE CHARGER WHEN CONNECTING OR DISCONNECTING LEADS TO AVOID SPARKING AS HIGHLY INFLAMMABLE HYDROGEN GAS IS RELEASED IN THE PROCESS OF BATTERY CHARGING.**

---

## PLEASE READ BEFORE USING THIS UNIT

1. Battery acid is highly corrosive. If spillage occurs, wipe off immediately and wash copiously with water. Particularly avoid contact with the eyes, but if this occurs, you must seek medical advice.
  2. Before charging ensure the battery terminals are clean and that the cells are filled with electrolyte to the correct level by adding distilled water where necessary.
  3. This product is not intended for use by persons with reduced physical, sensory or mental capabilities or lack of experience and knowledge.
  4. Children must not play with the charger.
  5. Do not expose this charger to rain.
  6. Never touch the negative and positive leads together.
  7. Never attempt any repairs yourself. If you have a problem with your charger contact your local Clarke dealer or contact [Service@Clarkeinternational.com](mailto:Service@Clarkeinternational.com)
  8. When charging is completed, ensure that the vehicle battery leads are secured to the proper terminals which should be clean, and lightly smeared with petroleum jelly to prevent corrosion. Finally, re-check the electrolyte level.
- 



**WARNING: CERTAIN TYPES OF SEALED OR MAINTENANCE-FREE BATTERIES NEED EXTRA CARE WHEN CHARGING. PLEASE CONSULT THE BATTERY MANUFACTURERS INSTRUCTIONS BEFORE USING THIS UNIT.**

---



**WARNING: SINCE TOXIC FUMES MAY BE RELEASED DURING BATTERY CHARGING, ONLY USE THIS UNIT IN A WELL VENTILATED AREA.**

---

# ELECTRICAL CONNECTIONS



**WARNING! READ THESE ELECTRICAL SAFETY INSTRUCTIONS THOROUGHLY BEFORE CONNECTING THE PRODUCT TO THE MAINS SUPPLY.**

Before switching the product on, make sure that the voltage of your electricity supply is the same as that indicated on the rating plate. This product is designed to operate on 230VAC 50Hz. Connecting it to any other power source may cause damage.

This product may be fitted with a non-rewireable plug. If it is necessary to change the fuse in the plug, the fuse cover must be refitted. If the fuse cover becomes lost or damaged, the plug must not be used until a suitable replacement is obtained.

If the plug has to be changed because it is not suitable for your socket, or due to damage, it should be cut off and a replacement fitted, following the wiring instructions shown below. The old plug must be disposed of safely, as insertion into a mains socket could cause an electrical hazard.



**WARNING! THE WIRES IN THE POWER CABLE OF THIS PRODUCT ARE COLOURED IN ACCORDANCE WITH THE FOLLOWING CODE:  
Blue = Neutral    Brown = Live**

If the colours of the wires in the power cable of this product do not correspond with the markings on the terminals of your plug, proceed as follows.

- The wire which is coloured **Blue** must be connected to the terminal which is marked **N** or coloured **Black**.
- The wire which is coloured **Brown** must be connected to the terminal which is marked **L** or coloured **Red**.

**Plug must be BS1363/A approved.**

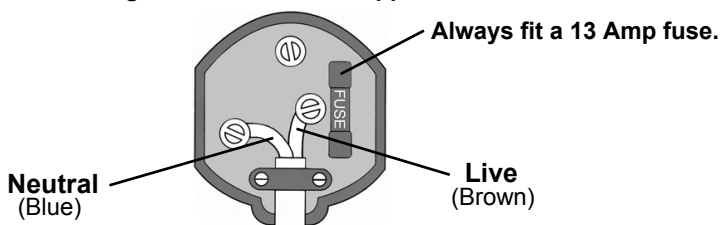

**Ensure that the outer sheath of the cable is firmly held by the clamp**

**We strongly recommend that this machine is connected to the mains supply via a Residual Current Device (RCD)**

If in any doubt, consult a qualified electrician. DO NOT attempt any repairs yourself.



**This symbol indicates that this is a Class II product, and does not require an earth connection.**

# OVERVIEW



1	Power LED (green)	8	Charging Current LEDs (12V white/24V blue)
2	Error LED (Wrong Connection) - red	9	Power On/Off Button
3	Charging LED (yellow)	10	Boost Selector
4	Charged LED (green)	11	Charging Current Selector
5	Boost LED (red)	12	Voltage Selector
6	NEGATIVE (BLACK) lead	13	POSITIVE (RED) lead
7	Digital Display		

The IBC20 is designed for charging all types of 12V and 24V lead-acid batteries including WET (flooded), GEL, MF (Maintenance Free), EFB (Enhanced flooded battery), and AGM (Absorbed Glass Mat) batteries.

The in-built microprocessor provides fast and safe charging using its safety features to protect against sparking, reversed polarity, short circuit, overcurrent, overcharge and over heating.

The auto-memory feature means that after powering on, the visual display will show the last selected mode (except BOOST mode).

Once connected, the charger will begin charging after approx 5 seconds.

The yellow CHARGE LED will be on during charging and this will be replaced by the FULL LED when charging is completed. If the charger remains connected, it will automatically switch from charging to maintenance status to maintain the batteries during periods of storage.

Pressing the VOLTAGE button will display the current voltage level of the battery.

During the desulphation (pulse) function the corresponding charging mode (12V/24V) LED will be on and all other LEDs off.

The IBC 20 charger has 10 modes. STANDBY, 12V/2A, 12V/4A, 12V/6A, 12V/8A, 12V/10A, 12V/15A, 24V/3.5A, 24V/7.5A, 12V BOOST. Do not operate the charger until you confirm the appropriate charge for your battery. If you choose 24V mode for a 12V battery the battery will be damaged.

---

## PREPARATION

---

1. It may be necessary to remove the battery from a vehicle to charge it.
  - Always remove the grounded terminal from the battery first.
  - Ensure all accessories in the vehicle are switched off to prevent sparking.
2. Clean the battery terminals. Be careful to keep any corrosive matter from coming in contact with eyes.
3. If the battery can be topped up, add distilled water to each cell until the battery acid reaches the level specified by the battery manufacturer. This helps remove unwanted gas from the cell. Do not overfill. For a battery without cell caps, follow the manufacturer's instructions.
4. Study all the battery manufacturer's specified precautions: for example, removing or not removing cell caps while being charged, and recommended rates of charge.
5. Refer to the vehicle manual to find the voltage of the battery and make sure that the output is set to the correct voltage.
6. If the charger has adjustable charge rate, charge the battery initially at the lowest rate.

## CHARGER LOCATION

1. Place the charger as far away from the battery as possible.
2. Do not position the charger above the battery during the charging procedure. Gases from the battery will corrode and damage the charger.

3. Do not let battery acid drip on the charger when reading a hydrometer for specific gravity or when you fill the battery.
4. Do not use the charger in an enclosed space with reduced airflow.

## CONNECTING TO A BATTERY

---



**WARNING: A SPARK NEAR THE BATTERY MAY CAUSE BATTERY EXPLOSION.  
TO REDUCE THE RISK OF A SPARK NEAR THE BATTERY:**

- Turn off the charger before you connect/disconnect the DC output clips.
  - Do not let the clamps touch each other.
  - Attach the clamps to the battery terminals and make sure that you get a good connection.
- 

### WHEN THE BATTERY IS INSTALLED IN THE VEHICLE

1. Route the leads carefully to reduce the risk of damage by the bonnet, door, or engine parts.
2. Keep away from the fan blades, belts, pulleys, and other parts that can cause injury.
3. Check the polarity of the battery posts.
4. Refer to the vehicle manual to find out if the vehicle has a Negative or Positive earth.
  - For negative earth vehicles, connect the POSITIVE (RED) lead from the battery charger to the POSITIVE terminal on the battery. Connect the NEGATIVE (BLACK) lead to the vehicle chassis, engine block or suitable earthing point away from the battery. Do not connect the lead to the carburettor, (if fitted) fuel lines, or sheet metal body parts.
  - For positive earth vehicles, (very rare today) connect the NEGATIVE (BLACK) lead from the battery charger to the NEGATIVE terminal on the battery. Connect the POSITIVE (RED) lead to the vehicle chassis or engine block away from the battery. Do not connect the lead to the carburettor (if used) fuel lines, or sheet metal body parts.

**NOTE:** If the battery clamps are reversed, the ERROR LED will be on.

5. When charging is completed, switch off the charger and disconnect the plug from the power supply. Remove the lead from the vehicle chassis, and then remove the leads from the battery.

### WHEN THE BATTERY HAS BEEN REMOVED FROM THE VEHICLE

1. Make sure that you know the polarity of the battery posts.
2. Connect the POSITIVE (RED) lead to the POSITIVE post on the battery.

3. Reach over and connect the NEGATIVE (BLACK) lead at arms length to the NEGATIVE post on the battery.
4. When charging is completed, switch off the charger and disconnect the plug from the power supply. When you disconnect the charger from the battery always do it in the opposite order to the sequence of connection.

**NOTE:** A marine battery must be removed and charged on shore. To charge it on board requires equipment specially designed for marine use.

---

## THE CHARGING PROCESS

---

This charger has have a sophisticated computer system that performs a 7 - stage automatic charging cycle as follows:

### **STEP 1: DIAGNOSIS**

Checks that the battery has connected with the charger and also checks the battery voltage.

### **STEP 2: DESULPHATION**

If battery voltage is too low, this step programs automatically and generates a pulsing current to remove sulphate.

### **STEP 3: ANALYSE**

Checks if the battery voltage reaches the threshold after desulphation and charging begins if the battery voltage is OK.

### **STEP 4: SOFT START**

Charges with constant current.

### **STEP 5: BULK**

Charges with constant maximum current until battery voltage has reached the threshold.

### **STEP6: ABSORPTION**

A gradually declining current charge for maximum battery voltage.

### **STEP 7: ANALYSE**

Testing if the battery can hold a charge

### **STEP 8: MAINTENANCE**

Continuously monitors the battery and charging current and will intelligently adapt to the variable battery voltage.

After the full charging cycle, use this battery to start the vehicle's engine. If the engine does not start (excluding a defect with the vehicle its-self), it indicates this battery has insufficient storage capacity and needs to be replaced.



## CHARGING SETTINGS

The IBC20 has the following selectable charging settings:

MODE	DISPLAY	POWER LIGHT	BOOST LIGHT	EXPLANATION
STANDBY	-----	Blinks		Unit not charging or providing any power. If you want charging to pause, press the ON/OFF button & the unit will enter standby mode.
12V/2A	2A	Yellow On		Press the CURRENT button repeatedly until 2A is shown. This mode is recommended for 2-60 AH batteries.
12V/4A	4A	Yellow On		Press the CURRENT button repeatedly until 4A is shown. This mode is recommended for 2-120 AH batteries.
12V/6A	6A	Yellow On		Press the CURRENT button repeatedly until 6A is shown. This mode is recommended for 10-180 AH batteries.
12V/8A	8A	Yellow On		Press the CURRENT button repeatedly until 8A is shown. This mode is recommended for 20-240 AH batteries.
12V/10A	10A	Yellow On		Press the CURRENT button repeatedly until 10A is shown. This mode is recommended for 40-300 AH batteries.
12V/15A	15A	Yellow On		Press the CURRENT button repeatedly until 15A is shown. This mode is recommended for 50-400 AH batteries.
24V/3.5A	3.5A	Blue On		Press the VOLTAGE button to select 24V, then press the CURRENT button repeatedly until 3.5A is shown. This mode is recommended for 14-115 AH batteries.

MODE	DISPLAY	POWER LIGHT	BOOST LIGHT	EXPLANATION
24V/7.5A	7.5A	Blue On		Press the VOLTAGE button to select 24V, then press the CURRENT button repeatedly until 7.5A is shown. This mode is recommended for 25-200 AH batteries.
BOOST 12V/20A	FAS	Red On	On	When connected to the battery, unit can enter BOOST mode by pressing the BOOST button. It takes 5 minutes to charge.

## USING THE 12V BOOST FUNCTION

To operate BOOST, the charger must be connected to a 12V lead-acid battery with the battery clamps connected. For optimal results, allow boost to complete its 5-minute charge. After 300 seconds of boost the display will show "000" and it should be possible to start the vehicle (whether FULL light is illuminated or not). If unsuccessful when starting your vehicle, let the battery rest for 15 minutes and try boost again. Most vehicles will start with one boost. Do not use the boost function more than twice within a 24-hour period. If 2 boosts cannot successfully start your vehicle, have your battery replaced or evaluated by a local battery supplier.

---

## OPERATION

---

### TO CHARGE THE BATTERY

1. Connect the charger to the battery (see page 7).
2. Connect the charger to the mains supply.

If the charger senses an incorrectly connected battery the error display will indicate the fault as follows. The fault needs to be identified before you continue connecting the battery.

### ERROR CODES DISPLAYED

- E01: High temperature (with buzzer)
- E02: 1) Open Circuit (no load)
  - 2) Dirty battery posts
  - 3) Dead battery
  - 4) Output short circuit

- E03: Inappropriate charge mode (12V mode chosen for 24V battery)
- E04: Battery defective, battery cannot retain charge
- E05: Unsuccessful desulphation (Defective battery)
- E06: Reverse connection (with error LED)

## CHARGING TIME DURATION

Different battery capacity, residual voltage and charging current will all affect charging time. The following table is for guidance in the case of a fully discharged battery.

When charging is complete the green "CHARGED" LED will come on.

Battery Size / Ah	Approx. Time to Charge in Hours							
	12V						24V	
	2A	4A	6A	8A	10A	15A	3.5A	7.5A
4	2	1	-	-	-	-	-	-
14	7	3.5	2.3	1.8	-	-	-	-
25	12.5	6	4.2	3.5	2.5	-	-	-
30	15	7.5	5	4	3	2	15	7.5
40	20	9	6.7	5.5	4	2.7	18	9.5
50	25	10	8.3	6.5	5	3.4	20	10.5
60	30	12.5	10	8	6	4	-	16.5
100	-	15	16.7	12.5	10	6.7	-	25
120	-	26	20	15	12	8	-	-
180	-	-	30	22	18	12	-	-
230	-	-	-	30	23	15.3	-	-
300	-	-	-	-	30	20	-	-
400	-	-	-	-	-	25	-	-

Switch off the charger and disconnect the plug from the power socket.

Remove the leads from the battery as described on page 8 and store them onboard the charger with the mains lead.

## TROUBLESHOOTING

Problem	Cause	Solution
ERROR display E01 (with buzzer)	High temperature	After the internal temperature reduces the charger will automatically start charging again.
ERROR display E02	1) Open circuit 2) Dirty battery posts 3) Dead battery 4) Output short circuit	1) Connect the red and black clamps or ring terminals to the battery posts 2) Clean battery posts 3) Replace the battery with a new one immediately. 4) Disconnect red & black output terminals.
ERROR display E03	Charge mode is inappropriate ie, 12V mode for 24V battery	Choose correct mode for your battery
ERROR display E04	Battery cannot store electrical charge during the charging process.	Replace the battery with a new one.
ERROR display E05	Unsuccessful desulphation	Replace the battery with a new one.
ERROR display E06	Reverse connection	Connect to the correct polarity
Battery does not charge	Lack of AC input power.	Make sure that the charger is plugged into AC outlet and the POWER LED is lit.
Very slow charging	Charging a very cold battery.	If the battery being charged is extremely cold, it will not accept a high rate of charge, so the initial charge rate will be slow. The rate of charger will increase as the battery warms up. Never attempt to charge a frozen battery.

---

## CARE & MAINTANENCE

---

This battery charger requires minimal maintenance. As with any appliance or tool, a few common sense rules will prolong its working life.



**WARNING: ALWAYS BE SURE THE CHARGER IS UNPLUGGED BEFORE PERFORMING ANY MAINTENANCE OR CLEANING. ANY REPAIRS MUST BE DONE BY A QUALIFIED SERVICE TECHNICIAN.**

1. Wind up the leads when not in use. Examine the leads at regular intervals for damage and have them replaced if necessary.
2. Clean the case and leads if necessary with a moist cloth and clean any corrosion from the clamps with a solution of water and baking soda.

---

## SPECIFICATIONS

---

Model Number	IBC20
Input voltage/current	230V, 50Hz, 2.5A
Battery charging voltages:	12V & 24V
Power	350W Max
Output current	12VDC - 2A/4A/6A/8A/10A/15A 24VDC - 3.5A/7.5A
Efficiency	85% approx
IP Rating	IP20
Battery Capacity	2-400 Ah (12V), 14-200 Ah (24V)
Charging steps	8 steps (smart charger)
Current back drain	<5mA
Operating Temperature Range	-10 to 40°C
Dimensions (D x W x H)	155 x 237 x 236 mm
Weight	1.76 kg
Charging lead length (red& black)	1.2 M
Mains power cable length	1.7 M

# COMPONENT PARTS

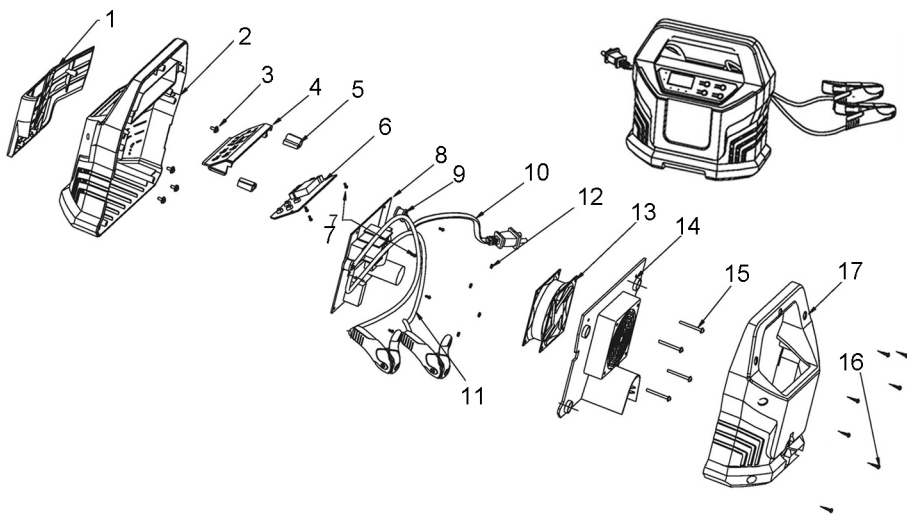

No	DESCRIPTION	No	DESCRIPTION
1	Front Panel	10	Power Cable
2	Front Cover	11	Extension Cable
3	Screw	12	Nuts
4	Function Panel	13	Fan Assembly
5	Locking Buckle	14	Partition Assembly
6	Circuit Board Control Module	15	Machine Screw
7	Screws	16	Screw
8	Main Circuit Board	17	Back Cover
9	Clip		

# DECLARATION OF CONFORMITY



**Clarke**<sup>®</sup>  
**INTERNATIONAL**

Hemnal Street, Epping, Essex CM16 4LG

## DECLARATION OF CONFORMITY

This is an important document and should be retained.

We hereby declare that this product(s) complies with the following directive(s):

2014/30/EU *Electromagnetic Compatibility Directive.*  
2014/35/EU *Low Voltage Equipment Directive.*  
2011/65/EU *Restriction of Hazardous substances.*

The following standards have been applied to the product(s):

EN 55014-1:2006 +A1:2009 +A2:2011, EN 55014-2:2015, EN 62233:2008,  
EN 61000-3-2:2014, EN 61000-3-3:2013, EN 60335-2-29:2004+A2:2010,  
EN 60335-1:2012 +A11:2014.

The technical documentation required to demonstrate that the product(s) meet(s) the requirement(s) of the aforementioned directive(s) has been compiled and is available for inspection by the relevant enforcement authorities.

The CE mark was first applied in: 2018

**Product Description:** Intelligent battery charger 20A, 12/24V  
**Model number(s):** IBC20  
**Serial / batch Number:** N/A  
**Date of Issue:** 26/04/2018

Signed:

J.A. Clarke  
Director

# A SELECTION FROM THE VAST RANGE OF

# Clarke®

## QUALITY PRODUCTS

### AIR COMPRESSORS

From DIY to industrial, Plus air tools, spray guns and accessories.

### GENERATORS

Prime duty or emergency standby for business, home and leisure.

### POWER WASHERS

Hot and cold, electric and engine driven - we have what you need

### WELDERS

Mig, Arc, Tig and Spot. From DIY to auto/industrial.

### METALWORKING

Drills, grinders and saws for DIY and professional use.

### WOODWORKING

Saws, sanders, lathes, mortisers and dust extraction.

### HYDRAULICS

Cranes, body repair kits, transmission jacks for all types of workshop use.

### WATER PUMPS

Submersible, electric and engine driven for DIY, agriculture and industry.

### POWERTOOLS

Angle grinders, cordless drill sets, saws and sanders.

### STARTERS/CHARGERS

All sizes for car and commercial use.



**PARTS & SERVICE: 0208 988 7400**  
E-mail: [Parts@clarkeinternational.com](mailto:Parts@clarkeinternational.com) or [Service@clarkeinternational.com](mailto:Service@clarkeinternational.com)  
**SALES: UK 01992 565333 or Export 00 44 (0)1992 565335**

**Clarke** INTERNATIONAL Hemnall Street, Epping, Essex CM16 4LG  
[www.clarkeinternational.com](http://www.clarkeinternational.com)